



SAFE IS THE NEW SMART



5MP Motorised Dome Network Camera

Model: GNCA-PD5M05-WSA (Pro Series)

- 30 FPS
- WDR 120dB
- TRIPLE STREAM
- H.265+
- ANR
- ONVIF
- STG
- VCA
- STARLIGHT
- SD CARD
- ALARM I/O
- BUILT IN MIC.
- AUDIO I/O
- IK10
- IP67
- PoE
- SONY STARVIS

Application Areas



Airports



Classrooms and Library



Hospitals



Police Stations



Government Office



Hotels

Indoor Motorised Dome Camera

Globus Infocom has been a leading technology provider in Security & Surveillance industry with a brand trust of almost 20 years. The company has been devising innovative and feasible security and surveillance solutions with an aim to address security concerns of organizations and provide them a holistic surveillance of their space. To take quality and reliability a step ahead, Globus Infocom introduces GNCA-PD5M05-WSA Indoor Dome Motorised Camera with 5MP resolution. Designed for unobtrusive and discreet surveillance, Dome Camera make for an easy to install and high- efficient security solution. Our high-end models include remote zoom, ultra-discreet design, high performance even in low light to power any organization's security & surveillance infrastructure at cost efficient prices.

Globus Indoor Motorised Dome Cameras specifically engineered for indoor as well as outdoor surveillance requirements. It offers standardised surveillance features like Triple Stream, AI Video Analytics, High Frame Per Second, Starlight Technology, Built-in-Mic, Audio In/Out, Alarm In/Out and many more for value added applications like round-the-clock surveillance of property, command and control centre, parking management, POS integration, etc.

Globus Indoor Dome Motorised Camera offers great details over an expansive area, be it indoor or outdoor, with the help of its 5x optical zoom and 1/2.7" progressive scan CMOS chip. It delivers high quality performance even in low light conditions, powered by Starlight as well as IR Imaging technology. Enhanced security features like signed firmware and secure boot ensures high-level security of your CCTV data and prevents tampering.

Designed with emphasis on its durability, Globus Indoor Dome Motorised CCTV Cameras are built using robust Metal housing that provides longer operational life and high installation flexibility. Aided by Automatic Varifocal Lens, it allows you to cover a wide area efficiently from remote locations.

Globus Indoor Motorised Dome Camera is completely user-configurable and can perform optimally under any scenario. Laced with a wide range of features, it serves as a crucial part of an organization's safety infrastructure.

30 FPS



Frame rates play a crucial role in determining the quality of video recorded by CCTV camera, users can reduce their bandwidth consumption while enhancing the detailing in the recorded images by choosing the cameras with high frames per second. Globus Network Cameras are equipped with imaging technology that captures videos in high frame rate of 30 FPS for smooth and even images of moving objects.

True Wide Dynamic Range

Globus Network CCTV Cameras are concocted with 120dB True WDR hence able to control the exposure as well as process the light values of each pixel in the image. Using 120dB WDR, the Globus range of cameras capture a balanced image with optimal exposure for all areas within the camera's field of view. In other words, Bright spots are toned down to prevent the image from being washed out, and the dark images are augmented to expose the objects in the shadows. This, in turn, enables the camera to go in places that would normally require expensive lighting controls/equipment.

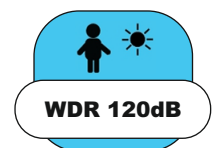

Triple Stream



Globus Network CCTV Cameras support multiple streams allowing a single camera to transmit triple streams at different resolutions, frame rates and codecs. It preserves the client-side bandwidth and processing power providing a wide extensive usage with a single installation itself. Triple streams provide much more flexibility to users by allowing different data streams to be sent simultaneously for smoother video streaming.

Globus Network Cameras support triple streams:

- Primary stream: full resolution
- Secondary stream: low resolution
- Tertiary stream: flexible choice (low or dynamic resolution).

H.265+ Compression Technology



The optimized version of H.265 compression technology, it uses a scene-adaptive encoding technology, dynamic ROI, intelligent noise reduction, flexible multi-frame reference, etc. to deliver high quality images while utilizing lower bandwidth and storage space. It reduces the bit rate and storage requirements of the recorded videos by up to 70% as compared to its predecessor.

ANR Technology

Globus Network Cameras support the Automatic Network Replenishment (ANR) feature i.e. if the connection between NVR and cameras is lost, the camera would start continuous recording and store videos in SD card instead of NVR. Then after reconnection, NVR automatically retrieves missed continuous videos from camera SD card in a period of time to prevent data missing. This feature enables user to use retrieve recorded data seamlessly and without any interruption. Thus, all of video recordings would be saved even network fails temporarily.

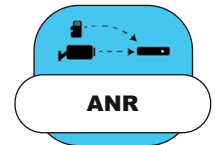

ONVIF STG



Globus Security Systems support ONVIF profiles S,T and G to ensure effective interoperability of our Network Cameras with other industry products. All our IP products are 100% ONVIF compliant and support all the features like video & audio streaming, pan-tilt-zoom control & relay output, site info & configuration, event & alarm management, etc

AI powered Video Content Analytics

The inbuilt AI-powered Video Analytics packs cutting-edge concepts and delivers more efficient, streamlined and hassle-free video assessment. It deploys artificial intelligence to cameras by analysing video content in real-time and fetches suitable inferences. It reliably detects, tracks and analyses object in its field of view and alerts users with preset alarms on incidents. A smart system of alarm rules out false alarms to minimum and makes surveillance from Globus Network Cameras more automated requiring minimal human intervention. Clubbed with features like Advanced motion detection, Camera tampering detection, People counting, Region entrance detection, Region departure detection, Line crossing detection, Loitering detection, Human presence detection, Left Object detection, Object removal detection, etc, Globus AI-Powered Video Analytics makes for a holistic and all-inclusive surveillance solution for every organization's security requirements.



Starlight Technology



Powered by Starlight Technology, Globus Network Cameras are designed specifically to perform even under challenging lighting conditions. Our cameras offer astounding light sensitivity, colour rendition even in low light down 0.001 lux. It uses its optical features to balance light throughout the scene and produce coloured images in dark environments. Our cameras produce full colour images in the dark with utmost detail where most of the conventional counterparts switch to monochrome. Aided by Starlight technology combined with other impressive technical specifications, Globus Network Cameras are the ultimate 24x7 surveillance cameras in the market.

Edge based SD Card Recording

To increase its usability, Globus Network Cameras come with Edge SD Card Recording support. This feature also serves as a saviour during network or server burnouts.

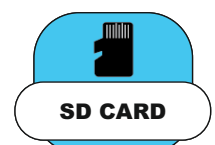

Alarm In/Alarm Out

For efficient, smart and responsive event management, Globus Network Video Recorders supports Alarm-In and Alarm-Out functionality. This enterprise-level alarm triggering mechanism supports various alarms and alerts in case of specific events. It strengthens users' security and surveillance infrastructure and improves its overall efficiency.



Built-In Microphone



The in-built microphone of Globus Network Camera facilitates glitch-free audio communication between operators and visitors. Recorded or live audios can also be used as an alarm system in case of specific incidents like perimeter intrusion, object removal, loitering, etc.

Audio In/Audio Out

Users can connect microphone and speaker to capture audio, listen live, record audio and talk/or make announcement via Globus Network Cameras using the two-way audio communication feature of the device. This feature allows operators to alert, deter or inform visitors or intruders in case of certain incidents. Recorded audio can also be used as an alarm to deter trespassers and miscreants.



IK10



Globus range of Network cameras are among the highly protected range of cameras compliant to IK10 standards (EN 62262 and IEC 62262) which means that the camera can be used in applications with high rates of vandalism. In addition, a Security Camera that is IK10 rated will generally withstand a variety of elements better than commercial grade standard Dome or Bullet Style Cameras.

IP67

Globus Network Cameras are resistant to mild physical strain and impact for performing rigorously even under harsh outdoor conditions. The IP 67 rating of our cameras certifies that they are built to withstand harsh weather conditions like dust, sunlight, rain, etc., making them perfect fit even in unforgiving conditions.



Power Over Ethernet (PoE)

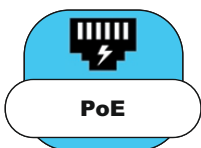

Power over Ethernet is an efficient way to power cameras with an Ethernet cord and also give them a direct network access. The functionality of PoE makes installation easier and cheaper by requiring only one cable. Unlike other connections, PoE also ensures your network cameras are always connected.

Sony Starvis Sensor

Globus Network CCTV Cameras are engineered with Sony Starvis Sensors, featuring back-illuminated pixel technology, these sensors are deemed to be one of the best-performing imaging technologies in the current market trends. Equipped with this sensor, Globus Network Cameras provide ultimate scenic detail, colour rendition and ultra-low-light performance with Prior Low Noise Circuit™ (PLNC) technology for better SNR. It features a sensitivity of 2000 mV or more per 1 μm² (color product, when imaging with a 706 cd/m² light source, F5.6 in 1 s accumulation equivalent) to render razor-sharp images with life-like detailing and colour reproduction. It deploys Multiple HDR filter to further increase the image quality.



5MP Motorised Dome Network Camera

Camera	
Image Sensor	1/2.7" Progressive Scan CMOS
Effective Pixel	2592x1944
Min. Illumination	Color: 0.001Lux@F1.2, B/W: 0Lux with IR on
Shutter Speed	1s ~ 1/100000s
Lens	2.7mm ~ 13.5mm, Automatic Focusing & Motorised Zoom Lens
Digital Zoom	16x Digital Zoom
Field of View	Horizontal: 103.4°~23.8°
Aperture	F1.6
Iris Type	Fixed Iris
Signal System	PAL/NTSC
Adjustment Angle	3 Axis
S/N Ratio	>60dB
Day/Night	ICR Filter Auto Switch
IR Distance	Up to 60m
Wavelength	850nm
Video	
Video Compression	H.265+, H.265, H.264+, H.264, MJPEG
Streaming Capability	Triple streams Individually configurable (H.265+,H.265,H.264)
Frame Rate	Main Stream: PAL: 25fps@2592×1944, 2592×1520, 2560×1440, 2304×1296, 50fps@ 1920×1080, 1280×720 NTSC:30fps@ 2592×1944, 2592×1520, 2560×1440, 2304×1296, 60fps@ 1920×1080, 1280×720
	Sub Stream: PAL: 25fps@704×576, 704×288, 640×480, 352×288 NTSC: 30fps@704×480, 704×240, 640×480, 352×240
	Third Stream: PAL: 25fps@1920×1080, 1280×720, 704×576, 704×288, 640×480, 352×288 NTSC: 30fps@1920×1080, 1280×720, 704×480, 704×240, 640×480, 352×240
Video Bit Rate	16Kbps~16Mbps (CBR/VBR Adjustable)
Image	
Wide Dynamic Range (WDR)	120dB WDR
Back Light Coompensation (BLC)	Supported
High Light Compensation (HLC)	Supported

Auto Exposure	Auto Level Control
Electronic Image Stabilization (EIS)	Supported
Privacy Masking	Supported (8 Areas, Rectangular)
ROI	Supported (8 Areas, Rectangular)
Defog	Supported
Digital Noise Reduction	2D/3D DNR
Image Setting	Brightness, Contrast, Saturation, Sharpness, Image Rotation
Image Enhancement Function	AWB, AGC, Corridor Mode
Audio	
Audio Compression	G.711A, G.711U, ADPCM, AAC
Audio Streaming	Two-Way Audio
Audio Input	1 Channel Input, Built-in-Mic
Audio Output	1 Channel Output
Events	
Event Trigger	Motion Detection, Mask Alarm, IP Address Conflict
Video Content Analytics (VCA)	Tripwire, Double Tripwire, Perimeter, Object Abandon, Object Lost, Loitering, Running, Parking, Crowded, People Counting, Crowded, On Duty Detection, Video Abnormal, Audio Abnormal, Heatmap, Face Capture(Face Detection), Safety Helmet Detection, Human/Vehicle Classification
Local Storage	
Memory Card Slot	Supported up to 512GB Micro SD.
ANR	Supported, Auto store video in SD card when NVR is disconnected; Upload video to NVR when connection is resumed.
Alarm Interface	
Alarm Input	2 Channel Input
Alarm Output	1 Channel Output
Network	
Ethernet	1*RJ45 10M/100M Ethernet Port
IP Support	Static, Dynamic
Protocol	TCP/IP, ICMP, HTTP, HTTPS, DHCP, DNS, DDNS, RTP, RTSP, RTCP, PPPoE, MULTICAST, UPnP, FTP, IPV4, NTP, SMTP, IGMP, 802.11x, QoS, IPV6, ARP, UDP, SNMP, SSL, SIP, Telnet, SNTP, RTMP, SFTP, NFS, Socks

AES Encryption	AES128 Supported
IP Address Filtering	Supported
Multi-Level User ID/ Password	Supported
Network Storage	NFS Supported
SIP/VoIP	Supported
Web Viewer	IE, Chrome, Firefox, Safari
Management Software Function	Globus CMS-lite
Mobile Application	GloView lite
System Compatibility	Onvif Profile S, T, G & SDK
User/Host	8
Environmental	
Power Supply	PoE (802.3af), DC 12V±10%
Power Consumption	7.5W Max, 9W Max(With IR on)
Operating Temperature	-40°C~65°C, Less than 95% RH
Ingress Protection	IP67
Vandal Resistance	IK10
Casing	Aluminium
Dimensions	143mmX124mm
Weight	0.95Kg

Exploded View

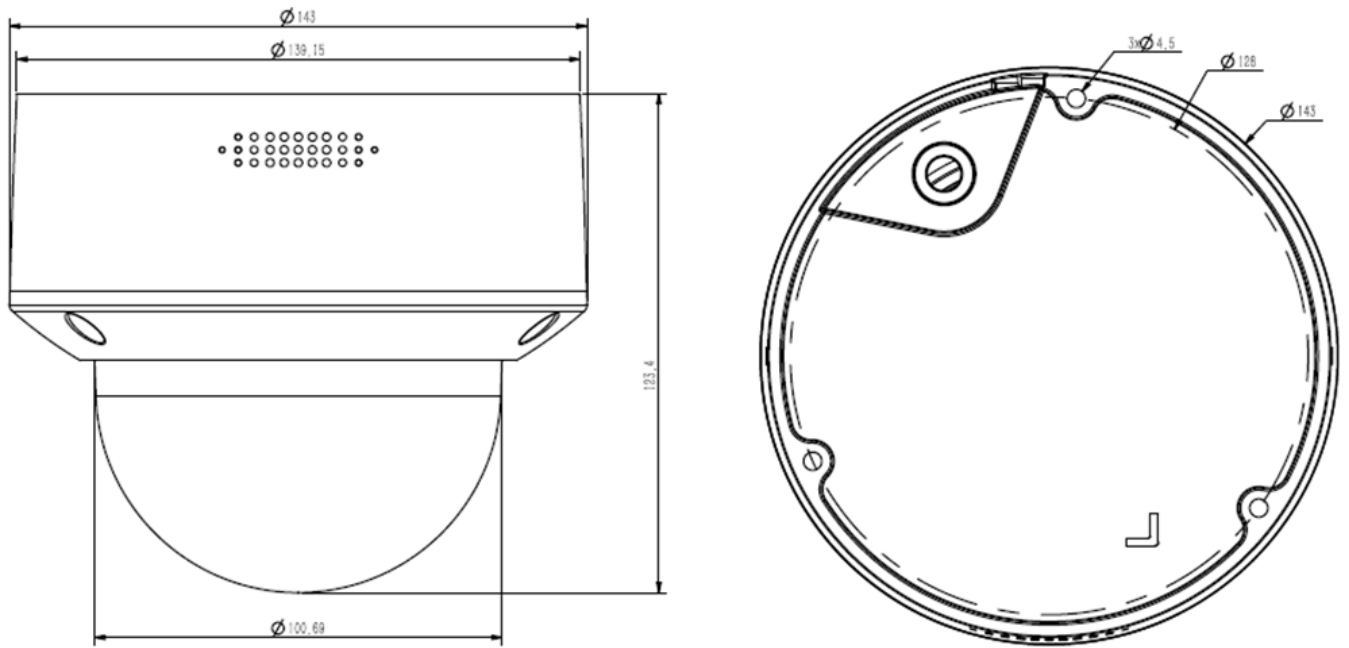

About Globus Infocom

Globus Infocom is a pioneer of technological solutions in the field of Education Technology, Collaborative Conferencing & Professional Displays, Security & Surveillance and Healthcare & Wellness.

The company houses one of the most elaborate range of security solutions including Network Dome Camera, Network Bullet Camera, PTZ Cameras, Fish Eye Cameras, NVRs, DVRs, Mobile Surveillance, Body Worn Cameras, Switches, PoE and related accessories.

With its in-house Research & Development team and the zeal for constant innovation, Globus has developed an insight to understand what 21st century Security & Surveillance market demands. Owing to its nationwide sales and service support, Globus Infocom, a proud Make in India brand, has amassed more than 25,000 customers with 50% of repeat order ratio.