



SAFE IS THE NEW SMART



5MP Motorised Bullet Network Camera

Model: GNCS-PB5M06-WSA (Pro Series)



Application Areas



City Surveillance



Railway Station



Highways



Traffic Light



Airports



Crowded Public Places

Outdoor Motorized Bullet Camera

Part of Globus Infocom's pioneering assortment of Security & Surveillance solutions, GNCS-PB5M06-WSA Outdoor Motorized Bullet Camera is a vandal proof, motorized varifocal and high-resolution camera for high-performance outdoor applications. Powered by the high-reliable Sony Starvis Sensor, it realizes high definition pictures in the visible-light and near-infrared light regions.

It supports H.265 and H.265+ intelligent video compression which furnishes high quality images while diminishing bandwidth and storage requirements 50% and 80% respectively. Additionally, coupled with smart features including multi-streams, super wide dynamic range, two-way audio, P-Iris technology, de-blur, etc., Globus Outdoor Motorized Bullet Camera provides an ideal solution for an organization's security & surveillance infrastructure.

Providing an affordable surveillance solution, Globus Outdoor Motorized Bullet Camera includes 120dB Super Wide Dynamic Range with inbuilt Infrared technology providing 60 metres visibility even in complete dark conditions. With motorized varifocal lens, this camera offers great flexibility in coverage and can be adjusted remotely.

Designed to deliver 24x7 performances, Globus Outdoor Motorized Bullet Camera is one of the most scalable, affordable and efficient CCTV cameras in the market.

Sony Starvis Sensor



Globus Network CCTV Cameras are engineered with Sony Starvis Sensors, featuring back-illuminated pixel technology, these sensors are deemed to be one of the best-performing imaging technologies in the current market trends. Equipped with this sensor, Globus Network Cameras provide ultimate scenic detail, colour rendition and ultra-low-light performance with Prior Low Noise Circuit™ (PLNC) technology for better SNR. It features a sensitivity of 2000 mV or more per 1 μm^2 (color product, when imaging with a 706 cd/m² light source, F5.6 in 1 s accumulation equivalent) to render razor-sharp images with life-like detailing and colour reproduction. It deploys Multiple HDR filter to further increase the image quality.

P-Iris

To override the shortcomings of an auto iris, Globus Network Cameras come equipped with P-Iris technology, which provides enhancements in colour, clarity, resolution and depth of field in captured images. Having a good depth of field is important while recording images in outdoor scenarios where objects at different distances are focussed simultaneously. In bright situations, P-Iris limits the complete closing of the iris to avoid blurring of images caused by diffraction of light. It combines the technology of both controlling the Iris and avoiding diffraction to create clear images in outdoor conditions. Globus Network Cameras lens uses a motor that controls the opening of the Iris precisely. Combined with software, it optimises the performance of a lens and the image sensor



30 FPS



Frame rates play a crucial role in determining the quality of video recorded by CCTV camera, users can reduce their bandwidth consumption while enhancing the detailing in the recorded images by choosing the cameras with high frames per second. Globus Network Cameras are equipped with imaging technology that captures videos in high frame rate of 30 FPS for smooth and even images of moving objects.

IK10

Globus range of Network cameras are among the highly protected range of cameras compliant to IK10 standards (EN 62262 and IEC 62262) which means that the camera can be used in applications with high rates of vandalism. In addition, a Security Camera that is IK10 rated will generally withstand a variety of elements better than commercial grade standard Dome or Bullet Style Cameras.



True Wide Dynamic Range

Globus Network CCTV Cameras are concocted with 120dB True WDR hence able to control the exposure as well as process the light values of each pixel in the image. Using 120dB WDR, the Globus range of cameras capture a balanced image with optimal exposure for all areas within the camera's field of view. In other words, Bright spots are toned down to prevent the image from being washed out, and the dark images are augmented to expose the objects in the shadows. This, in turn, enables the camera to go in places that would normally require expensive lighting controls/equipment.

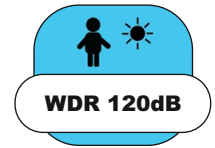

Triple Stream

Globus Network CCTV Cameras support multiple streams allowing a single camera to transmit triple streams at different resolutions, frame rates and codecs. It preserves the client-side bandwidth and processing power providing a wide extensive usage with a single installation itself. Triple streams provide much more flexibility to users by allowing different data streams to be sent simultaneously for smoother video streaming.



Globus Network Cameras support triple streams:

- Primary stream: full resolution
- Secondary stream: low resolution
- Tertiary stream: flexible choice (dynamic or low resolution).

H.265+ Compression Technology

The optimized version of H.265 compression technology, it uses a scene-adaptive encoding technology, dynamic ROI, intelligent noise reduction, flexible multi-frame reference, etc. to deliver high quality images while utilizing lower bandwidth and storage space. It reduces the bit rate and storage requirements of the recorded videos by up to 70% as compared to its predecessor.



Starlight Technology

Powered by Starlight Technology, Globus Network Cameras are designed specifically to perform even under challenging lighting conditions. Our cameras offer astounding light sensitivity, colour rendition even in low light down 0.001 lux. It uses its optical features to balance light throughout the scene and produce coloured images in dark environments. Our cameras produce full colour images in the dark with utmost detail where most of the conventional counterparts switch to monochrome. Aided by Starlight technology combined with other impressive technical specifications, Globus Network Cameras are the ultimate 24x7 surveillance cameras in the market.



AI powered Video Content Analytics

The inbuilt AI-powered Video Analytics packs cutting-edge concepts and delivers more efficient, streamlined and hassle-free video assessment. It deploys artificial intelligence to cameras by analysing video content in real-time and fetches suitable inferences. It reliably detects, tracks and analyses object in its field of view and alerts users with preset alarms on incidents. A smart system of alarm rules out false alarms to minimum and makes surveillance from Globus Network Cameras more automated requiring minimal human intervention. Clubbed with features like Advanced motion detection, Camera tampering detection, People counting, Region entrance detection, Region departure detection, Line crossing detection, Loitering detection, Human presence detection, Left Object detection, Object removal detection, etc, Globus AI-Powered Video Analytics makes for a holistic and all-inclusive surveillance solution for every organization's security requirements.



SIP/VoIP



Globus Network Cameras support the SIP Protocol to enable users to use each camera as an extension on a PBX. This feature enables operators to communicate verbally using the camera itself. It eliminates the need to install a paging system and combines both surveillance and communication into a single package. Owing to its SIP protocol, Globus Network Cameras enable users to make a call and transmit live-view as well as real-time sound to receiver's VOIP telephone in case certain incidents, which is faster and efficient than sending an email. Furthermore, it also reduces the traditional call costs.

ONVIF G, Q, S, T compliance

Globus Security Systems support ONVIF profiles G, Q, S and T to ensure effective interoperability of our Network Cameras with other industry products. All our IP products are 100% ONVIF compliant and support all the features like video & audio streaming, pan-tilt-zoom control & relay output, site info & configuration, event & alarm management, etc.



Edge based SD Card Recording

To increase its usability, Globus Network Cameras come with Edge SD Card Recording support. This feature also serves as a saviour during network or server burnouts.

Audio In/Audio Out

Users can connect microphone and speaker to capture audio, listen live, record audio and talk/or make announcement via Globus Network Cameras using the two-way audio communication feature of the device. This feature allows operators to alert, deter or inform visitors or intruders in case of certain incidents. Recorded audio can also be used as an alarm to deter trespassers and miscreants.



Alarm In/Alarm Out

For efficient, smart and responsive event management, Globus Network Video Recorders supports Alarm-In and Alarm-Out functionality. This enterprise-level alarm triggering mechanism supports various alarms and alerts in case of specific events. It strengthens users' security and surveillance infrastructure and improves its overall efficiency.

Power Over Ethernet (PoE)

Power over Ethernet is an efficient way to power cameras with an Ethernet cord and also give them a direct network access. The functionality of PoE makes installation easier and cheaper by requiring only one cable. Unlike other connections, PoE also ensures your network cameras are always connected.

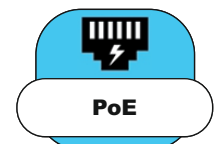

IP68



This Globus Network Camera is Industrial grade, extremely weather proof, and made of much higher end materials than inexpensive consumer grade cameras. This range of Globus Network Camera is certified to withstand dust, dirt and sand, as well as being resistant to water submersion up to a maximum depth of 1.5 meters for up to thirty minutes and is ideally suited for rugged industrial applications.

5MP Motorised Bullet Network Camera

Camera	
Image Sensor	1/2.7" Progressive Scan CMOS
Effective Pixel	2592x1944
RAM/ROM	512MB/128MB
Min. Illumination	Color: 0.001Lux@F1.2, B/W: 0Lux with IR on
Shutter Speed	1s ~ 1/100000s
Lens	2.7mm ~ 13.5mm, Automatic Focusing & Motorised Zoom Lens
Optical Zoom	5x Optical Motorised Zoom
Digital Zoom	16x Digital Zoom
Field of View	Horizontal: 89°~30° Vertical: 66°~22° Diagonal: 111°~37°
Aperture	F1.2
Iris Type	P-Iris
Signal System	PAL/NTSC
Adjustment Angle	3 Axis
S/N Ratio	>60dB
Day/Night	ICR Filter Auto Switch
IR Distance	Up to 60m
Wavelength	850nm
Video	
Video Compression	H.265+, H.265, H.264+, H.264, MJPEG
Streaming Capability	Triple streams Individually configurable (H.265+,H.265,H.264)
Frame Rate	Primary Stream: 30fps@2592x1944, 45fps@2048x1536, 60fps@1920x1080
	Secondary Stream: 30fps@704x576, 640x480, 640x360, 352x288, 320x240, 320x192, 320x180
	Tertiary Stream: 30fps@1920x1080, 1280x720, 704x576, 640x480, 640x360, 320x240, 320x192, 320x180
Video Bit Rate	16Kbps~16Mbps (CBR/VBR Adjustable)
Image	
Wide Dynamic Range (WDR)	120dB WDR
Back Light Coapensation (BLC)	Supported

High Light Compensation (HLC)	Supported
Auto Exposure	Auto Level Control
Electronic Image Stabilization (EIS)	Supported
Privacy Masking	Supported (8 Areas, Rectangular)
ROI	Supported (8 Areas, Rectangular)
Defog	Supported
Digital Noise Reduction	2D/3D DNR
Image Setting	Brightness, Contrast, Saturation, Auto Gain, Sharpness, Image Rotation
Image Enhancement Function	AWB, AGC, Anti-flicker, Corridor Mode, Deblur, Watermark
Audio	
Audio Compression	G.711, AAC, G.722, G.726
Audio Streaming	Two-Way Audio
Audio Input	1 Channel Input
Audio Output	1 Channel Output
Events	
Event Trigger	Motion Detection, Network Disconnection, External Input, Audio Alarm, Pre/Post Alarm Buffer.
Event Action	FTP Upload, SMTP Upload, SD Card Record, External Output, SIP Phone, HTTP Notification.
Video Content Analytics (VCA)	Region Entrance, Region Exiting, Advanced Motion Detection, Tamper Detection, Line Crossing, Loitering, Human Detection, People Counting, Object Left, Object Removed.
Local Storage	
Memory Card Slot	Supported up to 256GB Micro SD.
ANR	Supported, Auto store video in SD card when NVR is disconnected; Upload video to NVR when connection is resumed.
Alarm Interface	
Alarm Input	1 Channel Input
Alarm Output	1 Channel Output
Network	
Ethernet	1*RJ45 10M/100M Ethernet Port
IP Support	Static, Dynamic

Protocol	Pv4/IPv6, ARP, TCP, UDP, RTCP, RTP, RTSP, RTMP, HTTP, HTTPS, DNS, DDNS, FTP, NTP, SMTP, SNMP, DHCP, UPnP, Bonjour, SIP, PPPoE, VLAN, 802.1x, QoS, IGMP, ICMP, SSL
AES Encryption	AES256 Supported
IP Address Filtering	Supported
Multi-Level User ID/ Password	Supported
Network Storage	NAS(Support NFS, SMB/CIFS)
SIP/VoIP	Supported
Web Viewer	IE, Chrome, Firefox, Safari
Management Software Function	Globus CMS-Pro
Mobile Application	GloView Pro
System Compatibility	Onvif Profile G, Q, S, T & API
User/Host	20
Environmental	
Power Supply	PoE (802.3af), DC 12V±10%
Power Consumption	5.5W Max, 11W Max(With IR on)
Operating Temperature	-40°C~65°C, Less than 95% RH
Ingress Protection	IP68
Vandal Resistance	IK10
Casing	Aluminium
Dimensions	134mmX126mmX285mm
Weight	1080g

Exploded View

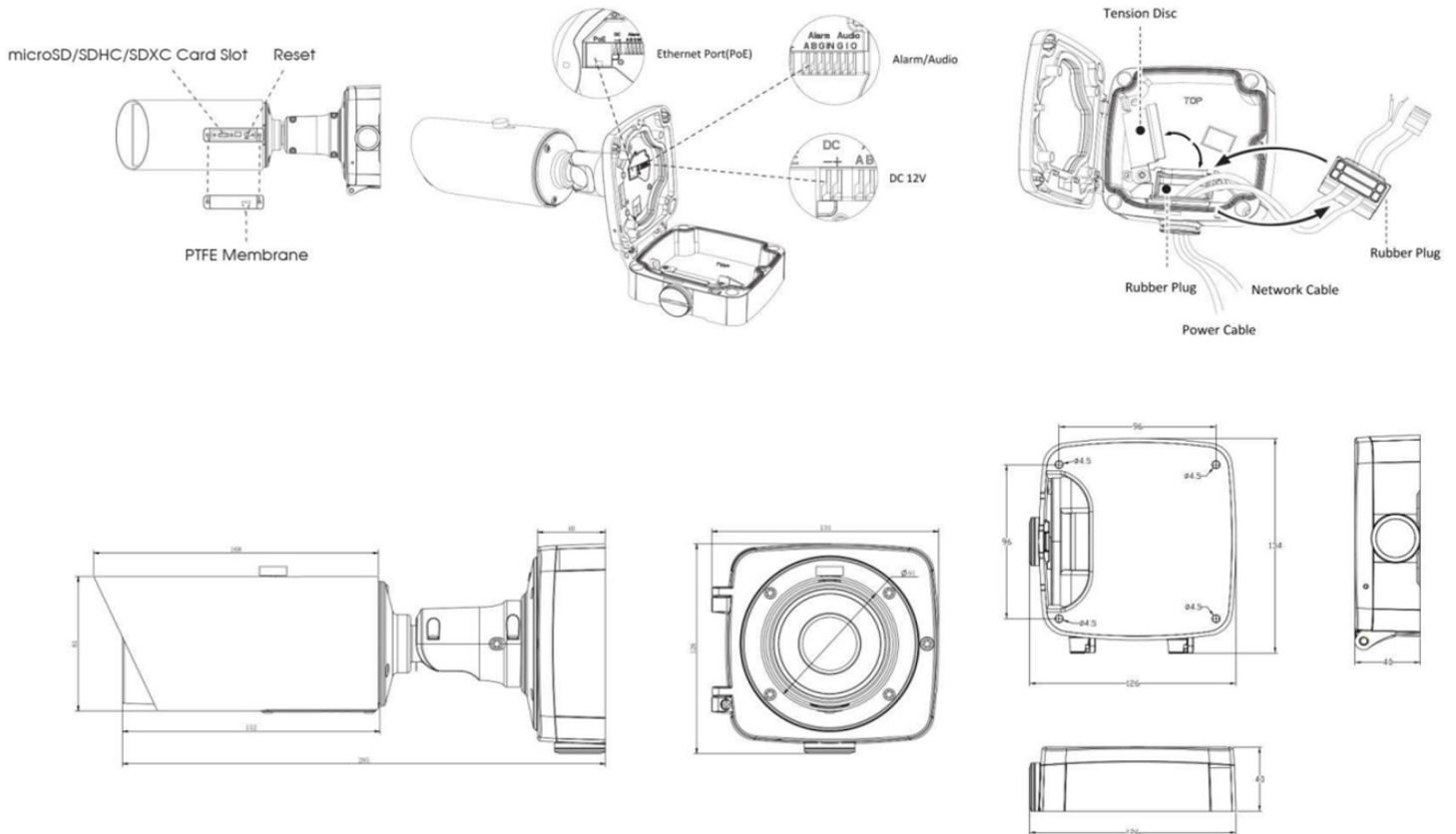

About Globus Infocom

Globus Infocom is a pioneer of technological solutions in the field of Education Technology, Collaborative Conferencing & Professional Displays, Security & Surveillance and Healthcare & Wellness.

The company houses one of the most elaborate range of security solutions including Network Dome Camera, Network Bullet Camera, PTZ Cameras, Fish Eye Cameras, NVRs, DVRs, Mobile Surveillance, Body Worn Cameras, Switches, PoE and related accessories.

With its in-house Research & Development team and the zeal for constant innovation, Globus has developed an insight to understand what 21st century Security & Surveillance market demands. Owing to its nationwide sales and service support, Globus Infocom, a proud Make in India brand, has amassed more than 25,000 customers with 50% of repeat order ratio.